

Standard Operating Procedures

Zones of Surveillance

When performing patron surveillance, Lifeguards should use the following Zone Charts to identify their assigned areas at the different Lifeguarding stations. Zone Charts have been created for a variety of activities and staffing levels, and should be followed when on shift. Zone Charts are also posted in the Lifeguard Office for employees to refer to when on shift. Lifeguards are responsible for monitoring all activities in their assigned area, including the surrounding deck areas and any areas of overlap between zones. Lifeguards must enforce all rules in a professional manner and respond to any emergencies in their zone within 30 seconds, based on the national recommendation set by the American Red Cross.

50M Zone Coverage—2RCY (double race-course—yards)

Activities Taking Place: Swimming Practice; Swimming Meet

- 50E Zone of Surveillance
 - 50W Zone of Surveillance
 - Area of Overlap
 - Halfway point that determines if both stands are required to be "up"
 - Area is closed off to swimmers due to blind spot
- 50E 50 Meter East Lifeguard Stand
- 50W 50 Meter West Lifeguard Stand

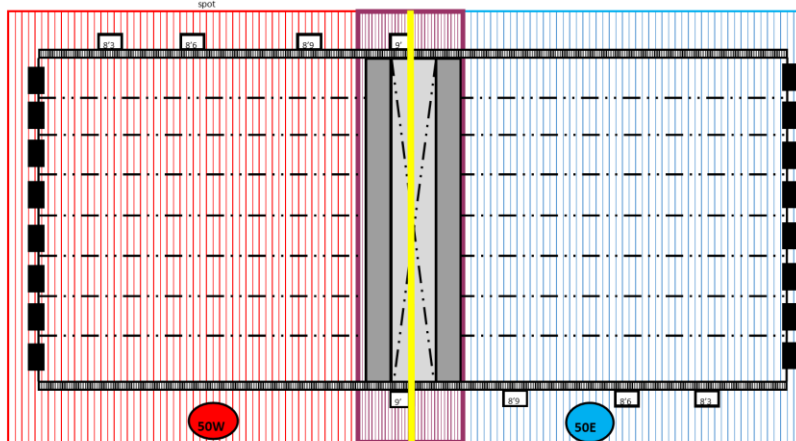

50M Zone Coverage—RCY (single race-course—yards)

Activities Taking Place: Swimming Practice; Swimming Meet

- 50E Zone of Surveillance
 - 50W Zone of Surveillance
 - Area of Overlap
 - Halfway point that determines if both stands are required to be "up"
- 50E 50 Meter East Lifeguard Stand
- 50W 50 Meter West Lifeguard Stand

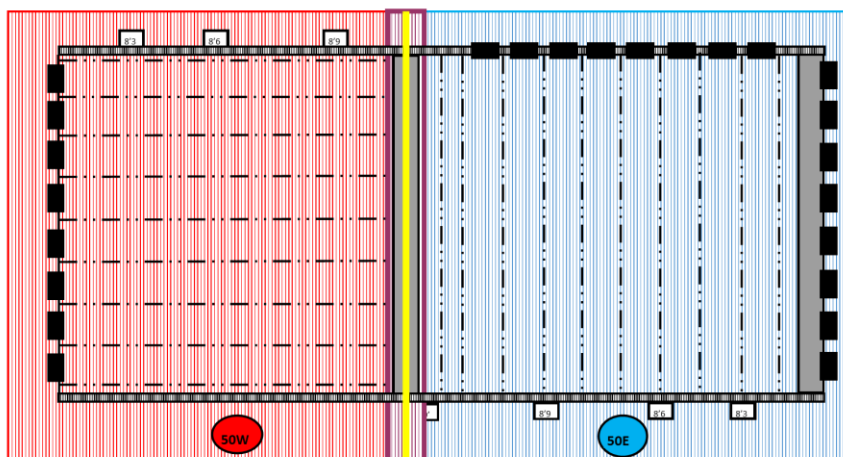

50M Zone Coverage—LCM (long-course: meters)

Activities Taking Place: Rec Swim; Swimming Practice; Swimming Meet

Note: there is no "halfway point" to determine if both stands are needed as when in Long Course, both lifeguards should be up at all times

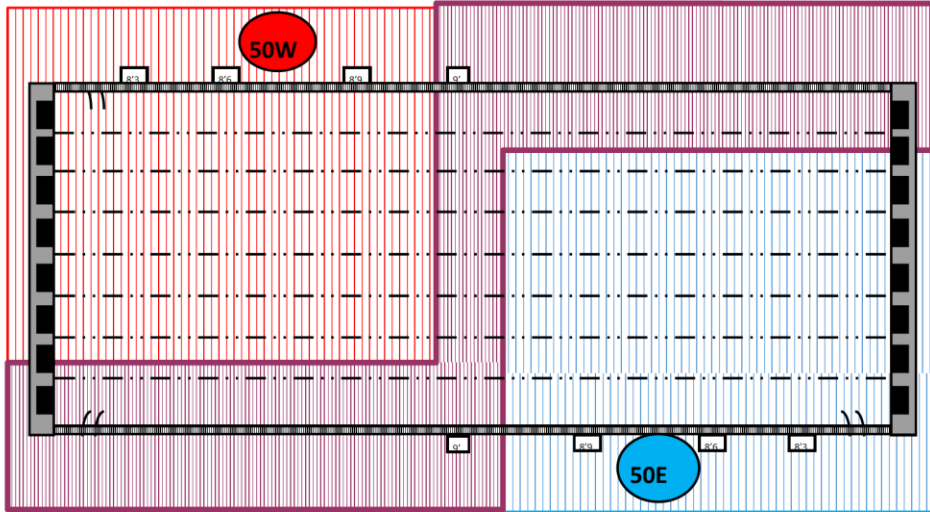
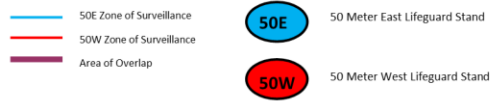

50M Zone Coverage—SCY (short course-yards)

Activities Taking Place: Swimming Practice; KINS with Rec Swim

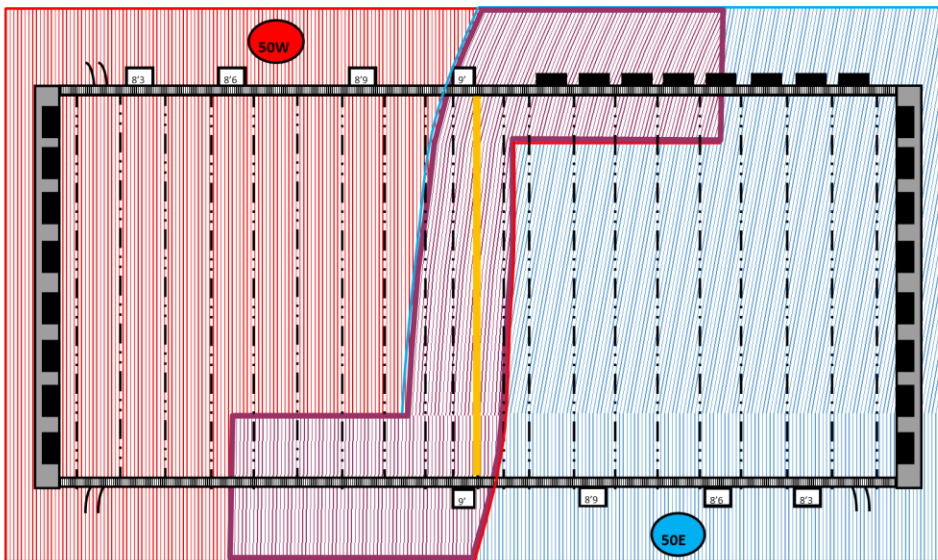
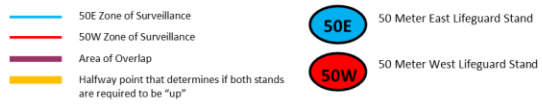

50M Zone Coverage—SCY (short course-yards)

Activities Taking Place: Rec Swim

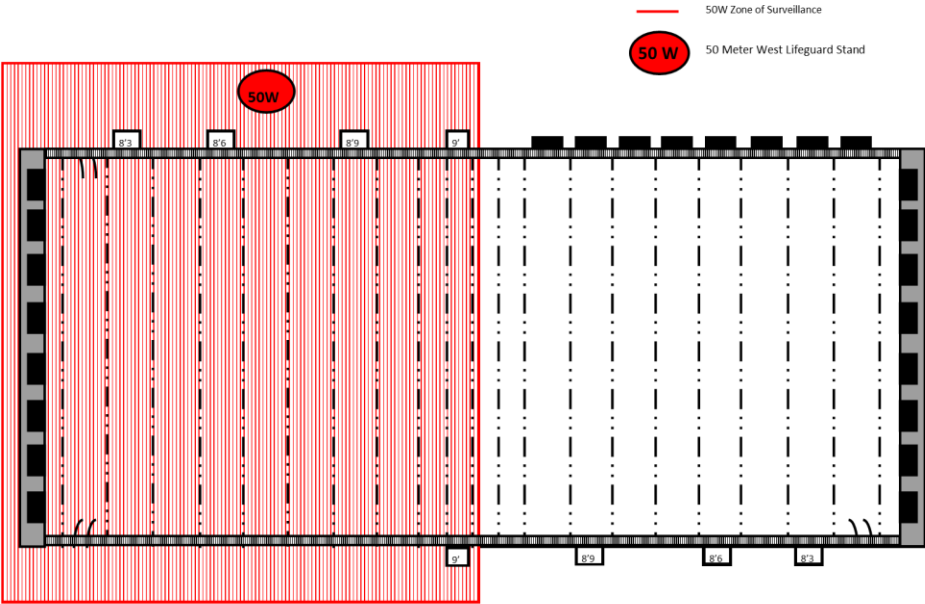

50M Zone Coverage—SCY (short course-yards)

Activities Taking Place: KINS Class, Club Swim Practice

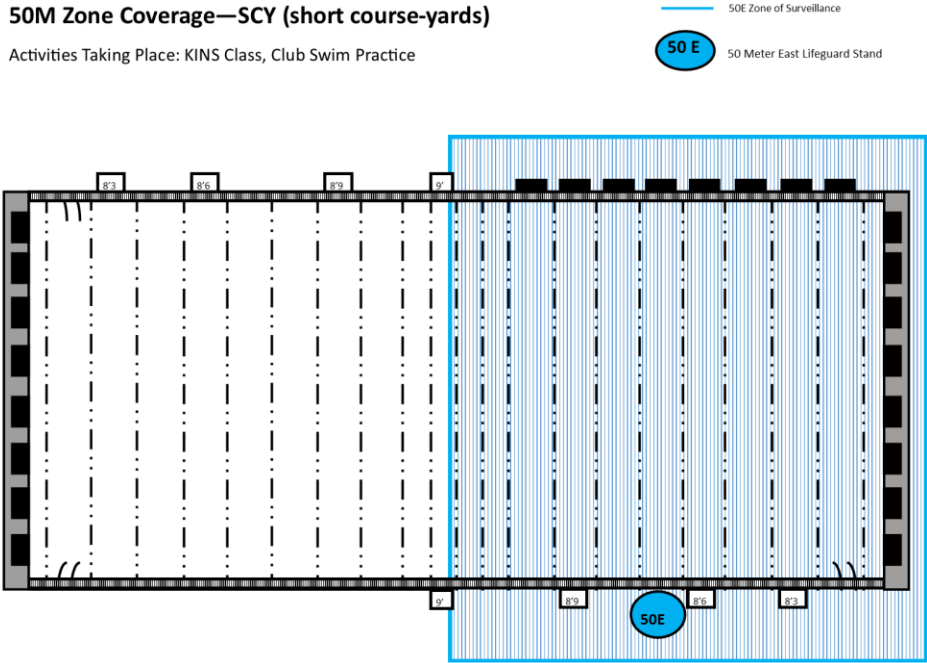

Diving Well (DW) Zone Coverage

Activities Taking Place: Diving Practice, Water Polo, Water Fitness

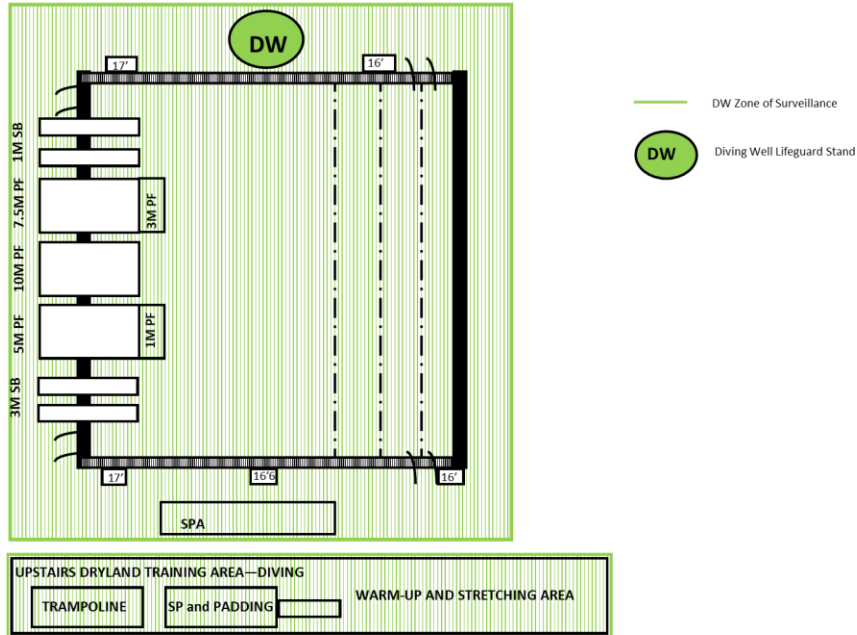

Diving Well (DW) Zone Coverage—Special Event

Activities Taking Place: Swim Camp, Large Athletic Event, High User Load

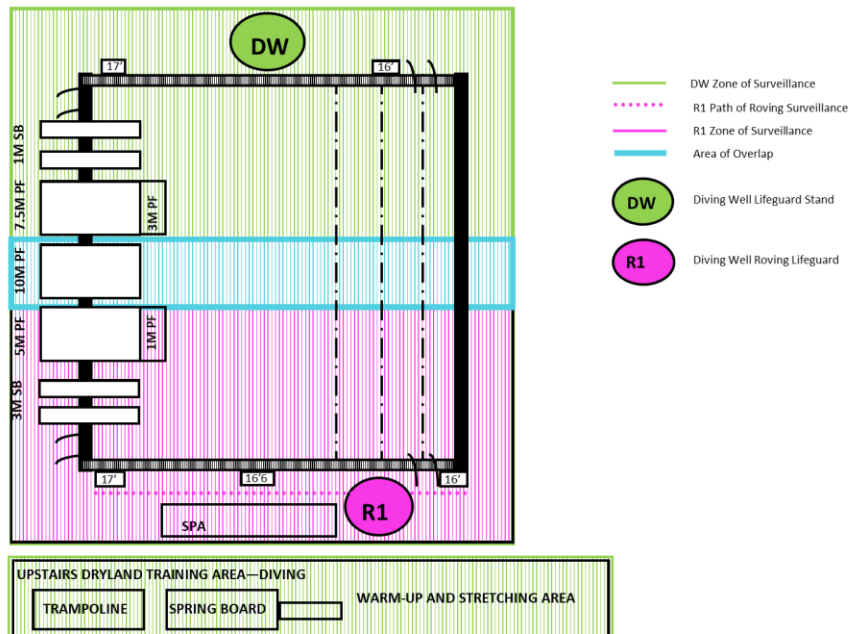

Rec Pool Zone Coverage

Activities Taking Place: Rec Swim; KINS; Kayaking; Water Fitness; Swimming Lessons

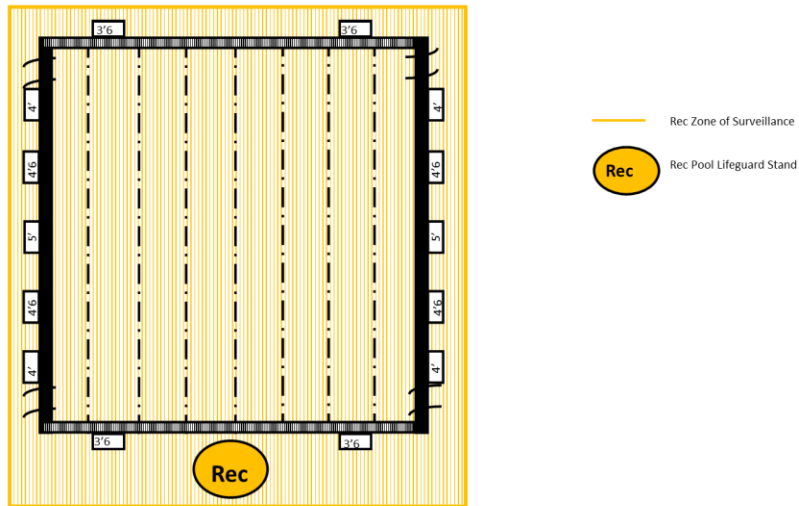

Rec Pool Zone Coverage—Special Event

Activities Taking Place: High User Load

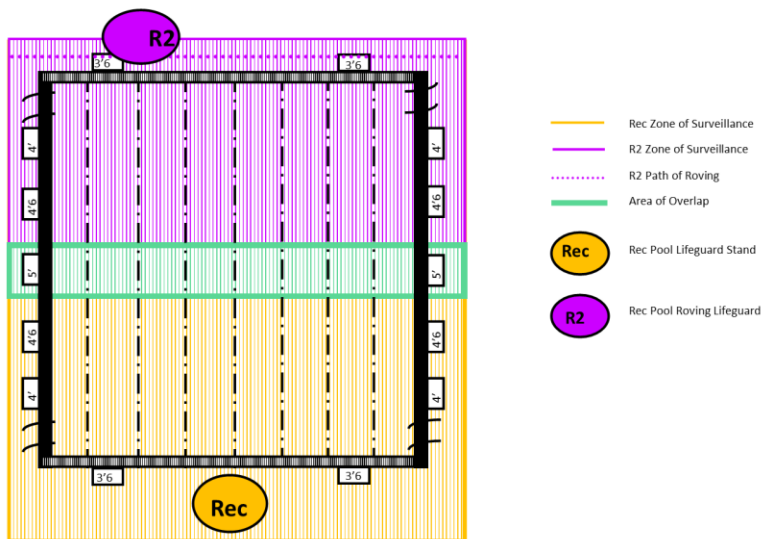

Rotation Procedures

- Lifeguards will rotate every 20 minutes.
 - Rotations will initiate at every 17, 37, and 57-minute marks to allow the final outbound lifeguard to reach the Lifeguard office at the 20, 40, and hour marks.
 - Lifeguards getting on shift will need to be ready to rotate at the 57-minute mark. If a Lifeguard arrives after the 57-minute mark they will be considered late to their shift.
- Lifeguards who are opening an area will go on stand as people begin gathering in the area to provide surveillance for the surrounding deck areas.
- If a stand leaves the path of rotation (i.e. a pool closes/group leaves), the Lifeguard who was stationed at the stand will go to the end of the rotation to the “Down Guard” position.
- The Down Guard will assist patrons or complete assigned cleaning/maintenance tasks.
 - If all tasks are completed and no assistance is needed, a Down Guard may complete homework or studying tasks.
- Rotation Expectations:
 - The Down Guard in the Lifeguard Office will initiate rotation at the designated times.
 - All Lifeguards will carry a rescue tube throughout rotation, scanning the area as they approach/exit a stand.
 - Rotations will have an overlap in surveillance between the outbound and inbound Lifeguards, with a clear transfer of surveillance duties using verbal cues.
 - All Lifeguards will follow the posted path of rotation.
 - From the point the Down Guard initiates rotation, to the point the last outbound Lifeguard reaches the Lifeguard Office, no more than 3 minutes should have passed.
 - Lifeguards should not complete any secondary or personal tasks when rotating/performing surveillance. Radio for a Manager if assistance is needed.

When on Surveillance:

- Lifeguard is rescue ready at all times while on surveillance:
 - Sit upright and maintain an active posture:
 - Lifeguard sits towards the front of the seat, leaning slightly forward, with both feet placed flat on the platform of the stand with no crossing of the legs or feet.
 - Rescue tube held correctly:
 - Rescue tube is positioned across the thighs, with the strap worn over the shoulder and across the chest, excess line is gathered and held in a hand, with both hands holding the rescue tube
 - The Lifeguard wears a Fox40 whistle on a breakaway lanyard around the neck in a manner that does not compromise the breakaway function
 - Whistles/lanyards should not be removed for any reason while on shift
 - The Lifeguard wears a fully stocked hip pack, which includes a personal resuscitation mask, properly sized non-latex gloves, and gauze pads.
 - Long hair is properly secured back
 - Hair that goes beyond the chin is completely secured
 - Hair that covers the eyes but does not go beyond the chin is secured using a half-up method or headband
 - The Lifeguard does not wear shoes when on surveillance, including when walking during rotations
 - Slip-on/slide-on shoes may be worn when walking rotation
- Lifeguard is seated in the Lifeguard station at all times

- Lifeguards may opt to stand when at the Rec Pool, however, they may not rove and must remain stationary next to the Lifeguard station to perform proper surveillance
 - Special assignments may require a Lifeguard to follow a roving pattern, and this will be designated by the Aquatics Professional Staff
- Lifeguards may not exit their stand for any reason unless it is to initiate an emergency response or another Lifeguard has taken over surveillance (such as when rotating)
- Scans assigned area of surveillance continuously:
 - Lifeguard uses continuous head and eye movements to search all areas of the surveillance zone
 - Lifeguard searches all areas of the zone, including:
 - The top, middle, and bottom surface of the water
 - The surrounding deck areas
 - The area of water directly in front of/below the Lifeguard stand
 - Scans the area when rotating into/out of the zone
 - The Lifeguard scans frequently to recognize an emergency within 10 seconds and respond within 20 seconds (30 seconds to perform the initial rescue)
- The Lifeguard uses tactics to avoid scanning challenges:
 - Changes posture/position periodically to fight monotony (example switches between sitting and standing every 5 minutes)
 - Alters position/posture to clearly search blind spots
 - Avoids distracting behaviors including but not limited to: talking, eating, losing focus, performing secondary duties, messing with hair, checking watch excessively, using smart watch or phone, or focusing on areas outside of the assigned zone
 - And others as listed in the Lifeguarding Participant Manual (p. 67-69)

Path of Rotation:

- **50E – 50 Meter East:** Stand closest to the hallway with the Elevator
 - Covers East Zone, including on-deck areas
- **50W – 50 Meter West:** Stand closest to the Diving Well
 - Covers West Zone, including on-deck areas and spectator seating
- **DW:** Diving Well Stand
 - Covers Well Zone, including on-deck areas, dryland training, and spectator seating
- **Rec:** Recreation Pool
 - Covers Rec Zone, including on-deck areas
- **Down Guard**
 - Stationed in the Lifeguard office; responsible for serving as an Additional Responder to any emergencies

Path of Rotation

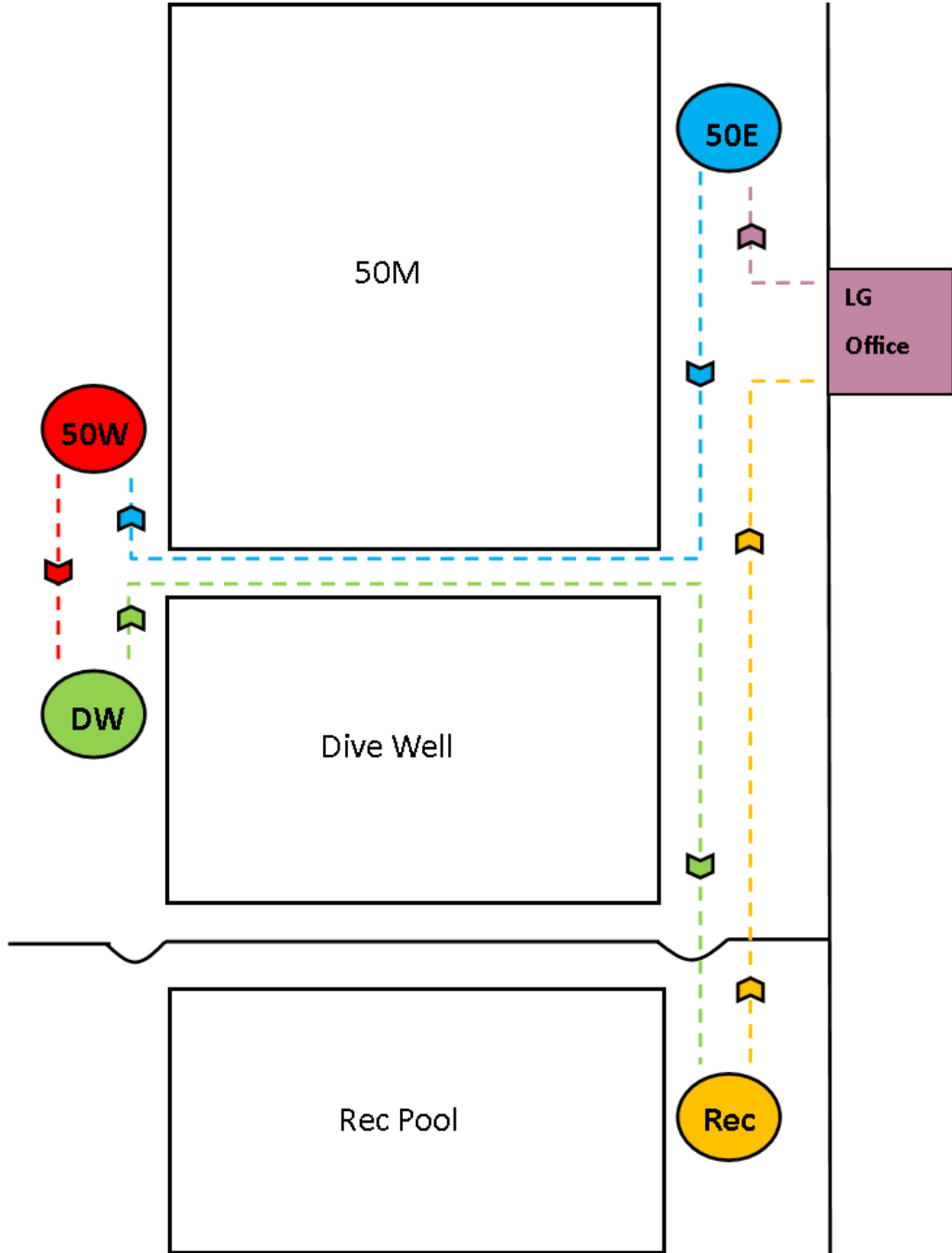

Opening Procedures

Aquatics Managers and Lifeguards are responsible for completing the following tasks at opening:

- Check out Aquatics Manager keys from the front (labeled with rescue tube key chain with “AQ Manager”)
- Unlock all doors
 - Spectator Seating (all doors)
 - Around the Natatorium (all doors except for those by 1M springboards in DW)
 - Leading into the Rec Pool (only when the Rec Pool is scheduled for Rec Swim)
- Turn on all Natatorium, Rec Pool (only when scheduled for Rec Swim), and Lifeguard Office lights
 - 50 for Rec Swim
 - 75 for UGA practice
 - 100 for events
- Turn on all ADA door motors by turning the bottom ‘Power’ button to ‘On’ (3 total)
- Conduct a deck walk and pump room check, verifying for the following:
 - Appropriate water levels – steadily flowing over the gutters
 - All pool ladders are in place
 - There are no foreign objects in the pools
 - There are no obvious signs of pump failure
 - All chemical systems appear to be operating correctly
 - All exterior-leading doors are securely shut
 - There are no active alarms for Becsys, pumps, boilers, doors, etc.
 - There are no hazardous/unsafe conditions
- Verify all pools are set to the proper orientation with backstroke flags in place
- Conduct a lane line change with the assistance of swim team if needed
- Ensure all Lifeguard stands, and rescue equipment are in their original placement
- Put away any left-out equipment and clear the deck of obstructions (e.g., lane line reels, CPR manikins, training backboards, lane line extenders, etc.)
- Check all pool chemicals and temperatures and submit the opening Chemical Check
- Test the ADA Lifts, stationary and portable, and return batteries to their appropriate chargers
- Ensure all Rec Swim Schedules and Pool Grids are posted and up to date
- Ensure all Pool Closed/Area Closed signs are set according to the schedules
- Complete the Opening Safety Checklist

Closing Procedures

Aquatics Managers and Lifeguards are responsible for completing the following tasks at closing:

- Clear all pools, deck, and spectator seating of patrons – you cannot leave until the deck is clear of patrons/athletes/coaches
- Conduct a deck walk and pump room check, verifying for the following:
 - Appropriate water levels – steadily flowing over the gutters
 - All pool ladders are in place
 - There are no foreign objects in the pools
 - There are no obvious signs of pump failure
 - All chemical systems appear to be operating correctly
 - All exterior-leading doors are securely shut
 - There are no active alarms for Becsys, pumps, boilers, doors, etc.
 - There are no hazardous/unsafe conditions
- Log all lost-and-found items
- Rotate lost-and-found items (Fridays at closing)
- Clean the deck of trash and messes

- Put away any left-out equipment and clear the deck of obstructions (e.g., lane line reels, CPR manikins, training backboards, lane line extenders, etc.) (including lane lines unless needed for a lane line change the following morning)
- Prepare the 50M pool for a lane line change if needed
- Consolidate all trash into one trash can
- Ensure all Lifeguard stands, and rescue equipment are in their original placement
- Lock all doors in Spectator Seating, around the Natatorium, and around the Rec Pool
- Turn off all ADA door motors by turning the bottom 'Power' button to 'Off' (3 total)
- Turn off all diving heaters and close the diving cage
- Ensure all Pool Closed Signs are placed in front of each pool
- Sanitize all hip packs, rescue tubes, walkie talkies, and Manager radio
- Clean and organize the Lifeguard office
- Place all ADA Lift batteries on chargers
- Place all walkie talkies and Manager Radio on chargers
- Hang hip packs on the Lifeguard Office door
- Hang all rescue tubes inside the Lifeguard Office on the hooks in the back
- Conduct the Closing Safety Checklist
- Turn off all Natatorium, Rec Pool, and Lifeguard Office lights
- Return Aquatics Manager keys to the front

Safety Checklists

Aquatics staff members will be expected to conduct regular safety inspections at opening, during daily operations, and at closing. A safety checklist is to be completed for each inspection:

- Opening Checklist
- Quick Check
- Closing Checklists

These Safety Checks include a visible and physical inspection of facility features, pool water, rescue and safety equipment, training equipment, diving boards, pool deck, and more. All items must be signed off for. Any item of concern that cannot be corrected by the Aquatics Manager must be noted on the checklist and reported to the Aquatics Professional Staff immediately.

Completion of checklists is the responsibility of the Aquatic Manager. These checklists will be maintained by the Aquatics Professional Staff for the facility's maintenance records. Lifeguards are expected to assist with Opening and Closing Checklists/ procedures at the Manager's discretion.

Cleaning and Maintenance

Aquatic Managers and Lifeguards are expected to assist the Maintenance Foreman and Maintenance Technician with regular cleaning and maintenance tasks. These tasks are a part of the Lifeguard's Secondary Duties and should not infringe upon surveillance duties at any point. These tasks will be designated by a cleaning checklist and should be completed at the designated times.

Completion of checklists is the responsibility of Lifeguards and the Aquatic Manager. These checklists will be maintained by the Aquatics Professional Staff for the facility's maintenance records.

Additional maintenance and cleaning tasks may be assigned by the Aquatics Professional Staff, and do not need to be documented unless specifically requested by a Professional Staff Member. The Aquatics Staff should only perform the cleaning and maintenance tasks within the scope of their position, and at the discretion/supervision of the Professional Staff.

Lost and Found Items

Items left behind by patrons, athletes, or spectators must be collected by the Aquatic staff at closing time every day. These items must be logged in the Lost and Found tracker using the designated binder and stored on top of the counter in the Lifeguard Office. Items that are considered to be of exceptional value (i.e., money, jewelry, identification, wallet, money, etc.) should be turned into the Facility Managers at closing.

Items may not be given out for patrons to use for any reason (ex: a patron cannot use a kickboard from the lost and found area unless it belongs to them). Any patron who comes to claim a lost and found item must be able to identify their item from description, and a staff member must then mark the item has been collected in the Lost and Found binder.

Lost and found items are to be rotated using the following system at closing every Friday night:

- Items collected during the week are moved to below the counter to Week 2 items
- Week 2 items are moved to the Safety Cage on the Week 3 items shelves
- Week 3 items are moved to the Week 4 shelves
- Week 4 items will remain for at least 1 week, after which a Program Assistant from Aquatics or Facilities will collect the items for donation

Staff members may not, under any circumstance, take items from the Lost and Found for their personal use (unless the item belongs to that employee).

During special events, there may be an event-specific lost and found station set up on the pool deck at the discretion of the Professional Staff. Items placed here between events, sessions, and/or days should not be logged in the Lost and Found Binder until closing on the last day of the event. After the event is finished, all lost and found items collected from the event will enter the regular lost and found system and be stored in the Week 4 section.

Administering Swim Tests and Life Jackets

Aquatic Managers and Lifeguards are responsible for ensuring weak/non-swimmers stay safe in, on, and around the water. If necessary, staff members are expected to fit swimmers for Coast Guard approved life jackets, which are located hanging on the wall in the Rec Pool.

Staff members may administer a swim test for anyone under the age of 18 years old. Anyone who does not pass the swim test must either wear a life jacket or be within arm's reach of an adult at all times in the water (if the child is a non-swimmer at 2 years old or younger, they must be in the arms of an adult at all times).

To perform a swim test, staff should complete the following steps:

1. Carry and wear a rescue tube
2. Select an area in a pool to conduct the swim test where the Lifeguard/Aquatic Manager can walk along-side with the rescue tube
3. Have the child perform the following:
 - a. Enter the water from the pool deck and fully submerge under water
 - b. Resurface and tread for 60 seconds
 - c. Turn and orient to an exit point approximately 20-25 yards away
 - d. Swim towards the exit using combined arm and leg actions on their front
 - e. Exit the water without using a ladder or other assistance
4. In order to pass, the child must complete all parts of the test without pausing or using a wall, lane line, or other person for support.

For anyone who is rescued by a Lifeguard from the water for any reason, if they remain in the facility, they must wear a life jacket for the remainder of their stay (special consideration given to athletes during competition).

Communication Signals

Lifeguards and Aquatic Managers are equipped with the following communication devices: Fox40 whistle, Aquatics walkie-talkies, Department radios, and an office phone. Communication devices should be used appropriately, when needed, to communicate with patrons, other Aquatics staff members, other Department staff members, and Emergency Services. When calling Emergency Services, staff should always try to use the landline office phone if possible.

Whistle Blasts:

- 1 Short Whistle: To get the attention of a patron
- 2 Short Whistles: To get the attention of a staff member
- 1 Long Whistle: To clear a pool
- 2 Short Whistles and 1 Long Whistle: To activate the EAP

Emergency Action Plans

Emergency Action Plans (EAPs) have been created for different types of emergencies that may be encountered in a campus recreation, indoor, aquatic environment. Staff are responsible for knowing the general steps of care as well as their specific roles in all EAPs. Staff are expected to follow the steps detailed in the EAPs to respond together as a team to any situations that may arise when on duty.

EAPs are reviewed and practiced during onboarding, and throughout employment at in-service trainings. EAPs have been posted in the Lifeguard Office for staff to review.

General Emergency Response

As an Aquatics employee there may be situations where you are required to respond to an emergency. These range from first aid emergencies to a swimmer in distress. The following includes your course of action to respond:

There are two methods for activating the EAP: the two way radio and whistle communication system. The method used will vary depending upon the location of the emergency.

1. The responding Aquatics staff member will alert the other staff members using the following whistle code:
 - i. Two short whistle blasts
 - ii. One long whistle blast
2. The Aquatics Manager will send the down lifeguard to the emergency area to assist in care/rescue of the distressed patron
 - i. The Aquatics Manager will then bring the following equipment to the area of the incident:
 - ii. Emergency Response Bag: includes the AED, BVM's, and First Aid supplies
 - iii. Backboard
 - iv. Walkie-talkie
3. The remaining staff members will clear the pools and move patrons away from the area of the emergency.

4. In the event of the emergency being life threatening, the Aquatics Manager will call 9-1-1 to request the aide of medical personnel (EMS)
5. The Aquatics Manager will then use the walkie-talkie to alert the Facility Manger of an emergency situation in the Gabrielsen Natatorium.
6. An Aquatics staff member will move to the loading dock to help direct EMS to the area of the accident
7. Aquatics staff members will provide care to the injured patron, within the scope of their training until EMS arrives.
8. Once EMS arrives, Aquatics staff members will assist in providing care and begin the injury reporting process.
9. After EMS has completed their care of the patron, the Aquatics Manger will alert Aquatics pro-staff members that an emergency situation has occurred.
10. All responding Aquatics staff members will de-brief following the incident to discuss how the situation was handled, what went well, what could be improved, etc.
11. If necessary, each responding Aquatics staff members will provide a written account of the incident.

Program Instructors should be familiar with the facility emergency action plan. Although the instructors are not responsible for activating the plan, they are responsible for the direct supervision of their students.

In the event of an emergency, Program Instructors should:

Collect their class.

Remove the class from the water or scene of accident.

Keep the class clear of the accident scene.

Maintain supervision of the class.

NOTE: If you are also a current Ramsey Student Center lifeguard, please allow posted guard to react. You must maintain the role of the Safety Class Instructor and should help in a secondary capacity as needed.

Special Situations:

- If a student injures themselves during a class, notify the lifeguard. The lifeguard will implement the Emergency Action Plan.
- If a student emits feces or vomit into a pool, notify the lifeguard. The lifeguard will clear the pool immediately. Safety Program Instructors should assist in clearing their class from the water and caring for the ill student.

When to Call EMS

The Aquatics Manager is responsible for determining if an ambulance is required and will activate the EMS system if additional help is needed. It is expected that an ambulance will be called when the following situations occur:

- The victim is or becomes unconscious
- Has severe difficulty breathing or is breathing in a strange manner and does not resolve on its own after 15 minutes
- Water inhalation after being recovered from under water
- Has chest pain, discomfort, or pressure lasting more than a few minutes, that goes away and comes back, or that radiates to the shoulder, arm, neck, jaw, stomach, or back
- Is bleeding severely

*Recreational Sports Aquatics Handbook
Reviewed July 2024*

- Has a nosebleed that lasts for longer than 10 minutes
- Persistent abdominal pain or pressure
- Is vomiting or passing blood
- Has seizures, a severe headache or slurred speech
- Appears to have been poisoned
- Suspected or obvious injuries to the head, neck, or spine
- Painful, swollen, deformed areas (suspected broken bone) or an open fracture above the hands or feet
- Expected exposure to hazardous chemicals or potentially infectious materials
- Condition is unclear or worsening

The aquatics manager is responsible for contacting the Assistant Director for Aquatics and Facility Managers any time an ambulance is required to assist with care.

Emergency Response Considerations

Refusal of Care: A victim that is conscious, alert and is over the age of 18 has the right to refuse medical treatment. Be sure to document that they refused additional care on the accident report and have them sign their full name on the space provided. If the victim does not wish to sign, have witnesses sign that they saw the refusal of care. If the victim is a minor, a parent or guardian can refuse care. Make sure you get the signature of that parent or guardian on the care refusal line. If the victim is a minor who is a member of one of our user groups, a coach's signature needs to be obtained if a parent is not present.

UGA Swimming and Diving Athlete: In the event an athlete is injured, becomes ill, or is involved in a drowning incident, Aquatics Lifeguards are responsible for initiating emergency response and care. Athletic Trainers (if on site and available) will assist with care, and potentially take over care depending on the emergency. The Aquatics Manager is responsible for completing the accident report and noting the athlete was released to the care of an Athletic Trainer. If EMS needs to be called for an emergency involving an athlete, the Aquatics Manager is responsible for calling EMS; Athletic Trainers do not replace the necessity of EMS.

Water Emergency During Athletic Competition: In the event an athlete suffers injury, becomes ill, or is involved in a drowning incident during an athletic event, Aquatics Lifeguards are responsible for initiating emergency response and care. Depending on the event, you may not be able to access the EAP using a whistle and may only use a walkie talkie to alert other staff members of the response. If the incident occurs during a swimming event, the rescuing Lifeguard may only enter the lane of the swimmer needing care. Lifeguards may NOT swim across the lanes during a swim event. The athlete's Athletic Trainer will likely take over care once the athlete has been removed from the water. Aquatics Lifeguards and the Aquatics Manager are responsible for ensuring all care is being provided until the Athletic Trainer assumes full care of the athlete. The Aquatics Manager is responsible for completing the accident report and noting the athlete was released to the care of their Athletic Trainer.

Spinal Backboarding Procedure During Athletic Competition: If the water emergency involves a suspected head, neck, or spinal injury in the 50M, Aquatics Lifeguards are responsible for beginning the spinal backboarding procedure, but they may not stop an event/heat that is actively running. Once the heat has concluded, the meet will cease operations as Aquatics Lifeguards complete the backboarding procedure using the high edge backboarding procedure from the bulkhead. If a suspected head, neck, or spinal injury occurs during a diving event, Lifeguards will complete the spinal backboarding procedure in the Diving Well.

Rescue Equipment

Aquatics Staff members have access to the following items in the event of an emergency:

- Backboard – 1 is stationed at each pool
- Shepherd's Crook – 1 is stationed at each pool
- Ring Buoy – 1 is stationed at each pool
- Rescue Tube – 1 is located at each Lifeguard stand, and Lifeguards on surveillance each carry a rescue tube; additional tubes are located inside the Lifeguard Office
- Hip Pack – worn by all Lifeguards and Managers on shift – containing:
 - Resuscitation Mask
 - Non-latex Gloves (at least 2 pairs of properly fitted gloves)
 - Band-aids
 - Gauze
- Go-Bag – located in the Lifeguard Office – containing:
 - AED
 - Adult BVM
 - Child BVM
 - Infant BVM
 - Adult Resuscitation Mask
 - Sterile dressing for bleeding control
 - Band Aids
 - First Aid cream
 - Glucose tablets/Juice
 - Instant Cold Packs
 - Tweezers
 - Alcohol Prep Pads
 - Hydrogen Peroxide
 - Non-latex Gloves
 - Towels
 - Medical Scissors
 - Medical Tape

Emergency Phone Numbers

The UGA Police Department is the primary contact for all campus emergencies. Calls will be routed to the appropriate campus and local first responders from UGA Police Communications.

When Using a Landline Phone:

- For on-campus numbers: Dial 2-6067 followed by the listed telephone number
- For off-campus numbers: Dial 9 followed by the listed area code and telephone number

**Cell Phones should only be used to make an emergency call if a landline phone is not accessible.*

Lifeguard Office Phone Number

- (706) 542 – 8462

Local and Departmental Services

- Emergency Services – Police, Fire, and Medical: 911
- UGA Police for Hearing Impaired (emergency): 706 542 – 1888
- UGA Police (non-emergency): (706) 542 – 1888
- UGA Environmental Safety Division: (706) 542 – 5801
- UGA Facilities Management Work Order Desk: (706) 542 – 7456
- UGA Facilities Management Work Order Desk (after hours/holidays): (706) 542 – 2200
- UGA Office of Emergency Preparedness: (706) 542 – 5845
- UGA Fire Safety Office (non-emergency): (706) 369 – 5706
- UGA Biosafety Office: (706) 542 – 2697
- UGA Radiation Safety Office: (706) 542 – 5801
- University Health Center: (706) 542 – 1162

Ramsey Student Center Professional Staff Numbers

- VACANT – Assistant Director for Aquatics
- VACANT - Senior Coordinator for Aquatics
- Hannah Giunta – Assistant Director for Facilities: (440) 935-6484
- Brian Williams – Senior Associate Director for Facilities: (912) 656-0429

Inclement Weather

Lightning

The Ramsey Student Center pools meet the proper grounding regulations, and the pump room equipment is secured indoors. In the event of lightning or thunder, the pools may remain operational.

Power Outage

If the weather is severe enough to cause a power outage, the Aquatics staff will need to clear all pools and safely escort patrons to a well-lit area in the facility. During a power outage, it is possible the pumps keeping water flowing in and out of the pools are no longer functioning. For health and safety reasons, the facility cannot allow swimmers in the water if circulation has ceased.

Electrical issues may also cause a power outage. If a power outage occurs not as the result of severe weather, staff should follow the same protocol as they would for an outage that results from inclement weather.

Tornado Warning

A tornado watch is issued by the National Weather Service when atmospheric conditions are ideal for tornados to occur. A watch does not require severe weather protocol to be enacted by the staff, but staff should prepare for severe weather protocol.

A tornado warning is issued when a tornado has been sighted, or indicated, by weather radar, in the area. A warning is more serious than a watch and should follow severe weather protocol until the severe weather has been cleared and the National Weather Service lifts the warning for the area.

Monitor local TV stations, radio stations, NOAA weather radio, weather related websites, etc., for severe weather updates.

- NOAA weather radio will automatically turn on in the event of severe weather.
- Listen to information about Athens-Clarke County and immediately relay information to managers on duty.

The main locker rooms on the first floor of the Ramsey Student Center have been designated as the facility's primary "Shelter in Place" locations. These locker rooms may be accessed from the pool deck by using the hallway next to the Natatorium and Rec Pool.

In the event a tornado warning is issued for the area, staff and patrons will need to shelter in place immediately. The Aquatics staff should clear all pools, spectator seating, dryland training, Classroom 119, and Family Restrooms, and redirect patrons to their gender-appropriate locker rooms. The on-duty Aquatics Manager will need to communicate with Facility Managers using the department Radio, to coordinate shelter-in-place protocol and assist with directing patrons to a shelter-in-place location. Once all patrons are secured in the main locker rooms, the Aquatics staff should grab the Aquatics Emergency Response Bag and join the patrons and other Departmental staff in their gender-specific locker rooms.

Once in the locker room, staff and patrons must remain and shelter in place until the Tornado Warning is no longer in effect. Patrons should be encouraged to stay in the protected areas until the All-Clear signal is given either from the Professional Staff or Facility Managers.

If a special event is taking place, and spectator seating is filled, it may not be possible to move everyone to the first floor. Assist Facility Managers in directing spectators out of the main activity area and into the hallway between the Volleyball Arena and the Natatorium. Instruct them to remain away from all glass windows and doors. Once spectators are in place in the hallway, meet all Aquatics staff, patrons, and athletes in the first-floor locker rooms.

Additional Overflow Areas:

- Boxing Studio Hallway
- Squash Courts A & B
- Custodial Hallway
- Room 119

Once an "all clear" has been given, the Aquatics staff should re-enter the pool area and prepare to resume daily operations. The Aquatics Manager should ensure all pools are still operational, that staff are ready to assume surveillance duties, and that all rescue equipment has been returned to the appropriate place prior to allowing patrons to enter the water.

Recreational Water Illness

The Ramsey Student Center Aquatics area follows the Model Aquatic Health Code (MAHC) that has been created by the U.S. Centers for Disease Control and Prevention (CDC) and the National Swimming Pool Foundation (NSPF). The MAHC has been developed to prevent drowning, injuries, and the spread of recreational water illnesses at public swimming pools and spas. The goal of the MAHC is to reduce outbreaks of recreational water illnesses (RWIs), drowning and injuries from pool chemicals.

RWIs include many types of infections that are caused by germs spread by swallowing, breathing in mists, having contact with contaminated water, and by chemicals in the water or chemicals that evaporate from the water and cause indoor air quality problems.

Preventative Measures

Chlorine serves as the primary disinfectant for the pools at the Ramsey Student Center. Certified Pool Operators (CPOs) are on the Aquatics Professional Staff and are responsible for maintaining appropriate chlorine levels in all pools, using the guidelines set by the Georgia Department of Public Health (DPH) in the Rules and Regulations: Public Swimming Pools, Spas, and Recreational Water Parks. Chlorine will be maintained at the following levels to help prevent RWIs:

- Pools: 1.0ppm – 10.0ppm
- Spa: 3.0ppm – 10.0ppm

To allow the chlorine to interact as a disinfectant, the pH of the pools is primarily stabilized using gaseous CO₂. Liquid Muriatic Acid may also be used on occasion to help serve as a pH buffer. Pool Operators will maintain the pH at the following levels based on the guidelines set by the Georgia DPH:

- All: 7.2 – 7.8

Procedures for Treating Contaminated Water

General Steps for All Contaminations

- Clear the pool of all patrons
- Notify Aquatics Professional Staff
- Use the appropriate personal protective equipment (PPE): disposable gloves, safety apron, safety gloves, safety boots, and/or safety goggles to remove potentially infectious materials from the water
- Raise Chlorine Levels
- Monitor
- Reopen once it is safe to do so

Steps for Formed Fecal Matter/Vomit

- Remove as much of the fecal/vomit matter as possible with a net or bucket
- Sanitize items used to remove fecal/vomit matter
- Raise/maintain Chlorine to at least a 2.0ppm, maintain a pH of 7.5 or less, and maintain pool circulation for at least 30 minutes
- Once the disinfection process is complete and the water is within safe chemical parameters, allow re-entry into the pool

Steps for Large Blood Spill

- Raise/maintain Chlorine to at least 2.0ppm, maintain a pH of 7.5 or less, and maintain pool circulation for at least 30 minutes
- Once the disinfection process is complete and the water is within safe chemical parameters, allow re-entry into the pool

Steps for Loose Fecal Matter

- Remove as much of the fecal matter as possible with a net or bucket
- Sanitize items used to remove fecal matter
- Raise and maintain Chlorine to 20.0ppm, maintain pH of 7.5 or less, and maintain pool circulation for at least 12.75 hours
- Backwash pool filter(s)
- Once the disinfection process is complete, water is within safe chemical parameters, and circulation has been re-established, allow re-entry into the pool

Procedures for Treating Contaminated Materials/Supplies/Surfaces

- Use the appropriate PPE: disposable gloves, safety apron, safety gloves, safety boots, and/or safety goggles
- For Small Items (can fit into a bucket):
 - o Place the contaminated item(s) in a diluted bleach solution (10%), or the facility provided Bioesque solution, and ensure all contaminated surfaces are submerged in the disinfectant solution

- Leave for at least 30 minutes
 - Remove the item(s) from the solution, rinse off with tap water, and leave to air dry
 - Pour remaining bleach solution down a drain that does NOT connect to the pool filtration system
 - For Large Items (cannot fit into a bucket)
 - Cover/Spray the item(s) in a concentrated bleach solution (100%) or the facility provided Bioesque solution, and ensure all contaminated surfaces have been covered
 - Leave for at least 1 minute
 - Rinse off with tap water, and leave to air dry
 - For Surfaces (floors, walls, etc.)
 - Cone off the area
 - Use absorbent materials to remove as much of the contaminating source as possible
 - Spray all contaminated surfaces with a disinfectant solution, either:
 - A diluted bleach solution (10%) (preferred method unless there is a special event that requires a quick decontamination process)
 - Leave for at least 30 minutes
 - Rinse off the area with tap water and leave to air dry
- OR
- A concentrated bleach solution (100%)
 - Leave for at least 1 minute
 - Rinse off the area with tap water and leave to air dry
- OR
- The facility provided Bioesque solution
 - Leave for at least 1 minute
 - Rinse off the area with tap water and leave to air dry

Biohazard/Blood Spill Clean-up Procedures

Identification:

Employees at risk of occupational exposure are those who have a certain level of risk to bodily fluids such as blood, saliva, fecal matter, etc. For the purpose of this plan these employees have been identified as all those who work for the Department of Recreational Sports.

Employer Responsibilities:

The Department of Recreational Sports is responsible for minimizing the risk of exposure to potentially infectious materials for all employees at risk of exposure.

Protection:

To protect yourself from exposure to potentially infectious material, you have been provided with various pieces of personal protective equipment. You must use the appropriate protective equipment anytime you suspect there is risk of coming into contact with potentially infectious materials. For your safety, the department has provided the following items: latex-free disposable gloves, safety goggles/glasses, rubber utility gloves, rubber utility boots, safety gowns/aprons, and face shields.

General Response Procedures:

If you are confronted with a situation that involves blood and/or other potentially infectious materials, utilize universal precautions/body substance isolation precautions. The Biohazard Clean-Up Kit can be found in the Lifeguard Office next to the Emergency Response Bag.

Treat all blood and bodily fluids as if they are infectious materials!

Contact the Aquatics Manager on duty and inform them to isolate the spill and the area to ensure that no one can walk into the area or inadvertently come into contact with blood or other body fluids or spread the fluids any further.

Use appropriate personal protective equipment: latex-free disposable gloves are the minimum amount of protection needed. Protective eyewear (safety goggles), a face shield, rubber/utility gloves, rubber/utility boots, and a safety apron are all available and recommended for use.

Contain any visible blood or body fluid. Prevent the fluid from spreading by absorbing with paper towels/absorbent powder/any-disposable absorbent material as needed. Wipe up spill from the outer edges to the inside. Place soiled absorbent materials into a trash bag. Clean up the mess so that no blood or bodily fluids are left to the visible eye.

Remove solidified material and place in the trash bag. If any spill is mixed with sharp objects, such as broken glass and needles, use a broom and dustpan to pick up the objects. If a broom and dustpan are not accessible, two pieces of cardboard may be used as an alternative. Do not use your hands.

Decontaminate the area. Use the provided Bioesque solution to cover all contaminated surfaces. Allow to air dry for at least 30 minutes. Afterwards, remove any extra decontaminate by wiping it up. Place all materials used to contain or disinfect a spill (including disposable PPE used) into the trash bag. Tie off the trash bag containing all contaminated materials, and place this into another trash bag. Securely fasten the outer trash bag and place into a waste container. Contact FMD to empty the waste container.

Once the area has been decontaminated, remove any barriers that were used to isolate the spill/area.

Re-usable personal protective equipment, such as safety goggles, rubber/utility gloves, rubber/utility boots, and safety apron will need to be decontaminated using the following guidelines:

- For Small Items (can fit into a bucket):
 - o Place the contaminated item(s) in a disinfectant, and ensure all contaminated surfaces are submerged in the bleach solution
 - o Leave for at least 30 minutes
 - o Remove the item(s) from the solution, rinse off with tap water, and leave to air dry
 - o Pour remaining disinfectant solution down a drain that does NOT connect to the pool filtration system
- For Large Items (cannot fit into a bucket)
 - o Cover/Spray the item(s) in a concentrated disinfectant solution, and ensure all contaminated surfaces have been covered
 - o Leave for at least 1 minute
 - o Rinse off with tap water, and leave to air dry

Wash your hands thoroughly with soap and water immediately after following the clean-up procedures/providing care. This is a basic precaution and must be done. Wash hands for at least 20 seconds, paying attention to the areas between fingers, under fingernails, backs of the hands, and the wrists in addition to the hand. After washing your hands, you may also use hand sanitizer. If you do not have immediate access to a hand washing station, use the sanitizer and wash your hands as soon as you are able to do so.

Exposure Protocol:

*Recreational Sports Aquatics Handbook
Reviewed July 2024*

Report all exposure incidents, regardless of how minor they appear to be, to your supervisor. If you have been exposed to blood, or believe you have been exposed to blood, wash off any blood from your skin with soap and warm water. If exposure has occurred to the eyes, using the emergency eyewash station in the pump room, flush your eyes for a minimum of 20 minutes. Contact your supervisor immediately and complete the exposure incident report form. A follow-up assessment by a physician may be required as part of the response protocol if deemed necessary by the department. If requested, you must attend an appointment with a physician for an assessment of the suspected exposure.